

The HSA-250 is our newest offering for Vertical Shrink Sleeve Labeling and Tamper Banding equipment. It was redesigned from the ground up using proven technology to provide repeatable performance and improve ease of use. This robust machine is intended to be an integral part of your daily packaging operations.

The HSA-250 applicator is a medium-to-high speed machine, capable of running a wide range of shapes and sizes up to 250 products per minute. This machine design uses proven components from our higher speed machines, including a mandrel in combination with servo motion control on the feed wheels and knife assembly for precise feeding and cutting of the film. Changeover has been improved and simplified using a combination of digital counters and scales to get you back in production sooner. The machine's design features provide a great solution that can be used for flexible packaging in several industries: including food, beverage, pharmaceutical, home care, cosmetics, and many more.

BENEFITS

- Reliable Performance with Servos
- Size Range and Material Type Flexibility
- "Side Winder" Knife Design for Great Cut Performance and Longer Blade Life
- Simplified and Repeatable Tool-Less Changeovers with Quick Change Tooling
- Foolproof Wheel Tensioning Devices
- Print Registration or User Input for Control of Cut Length
- Airbox Zero Tension Film Control – Reduces Mechanical Components and Unneeded Tension
- Self-Contained Design with Dual Roll Unwind Station

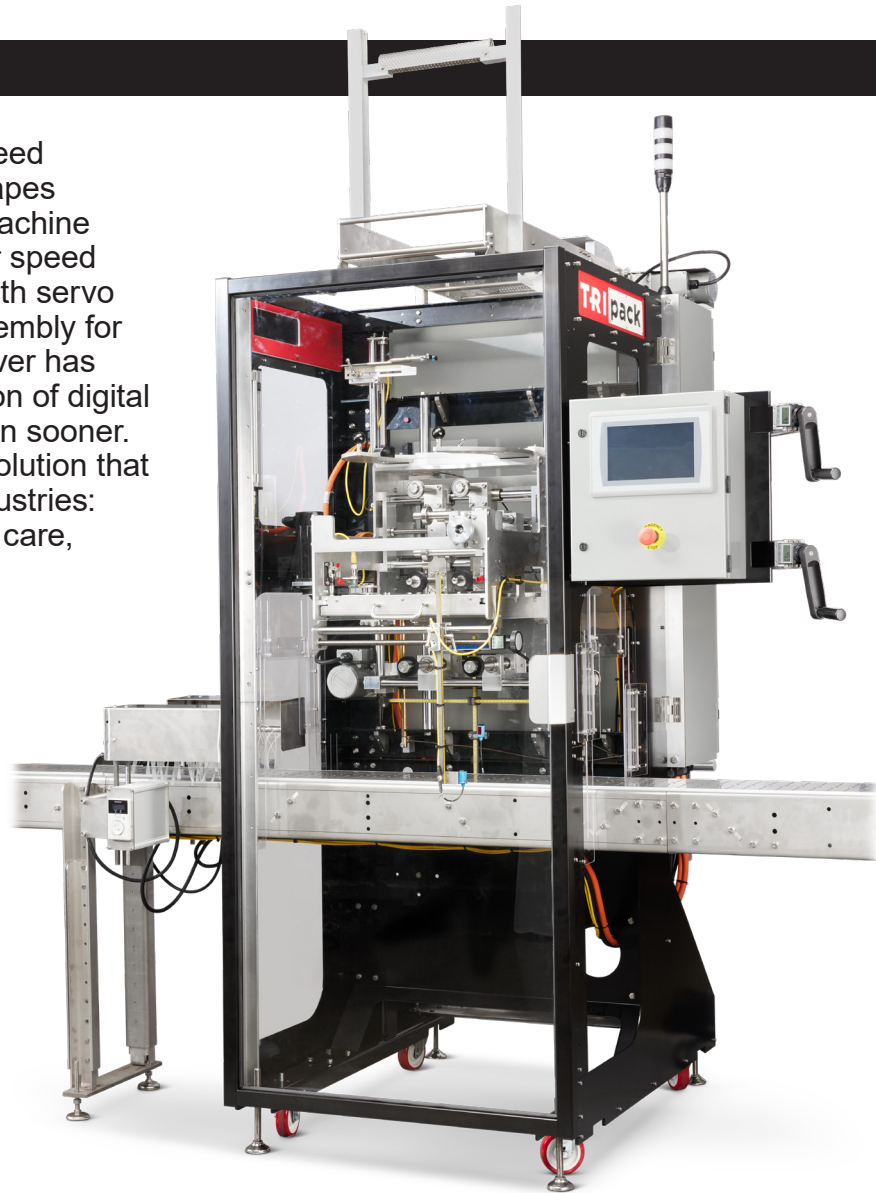

Like all Tripack Applicators, the HSA-250 has full complement of options, including customized product handling solutions, film accumulation devices, and shrink tunnels. Buy the applicator or integrate it into a full Tripack system!

SHRINK APPLICATIONS



PRIMARY SLEEVE



FULL BODY OVER-THE-CAP SLEEVE



TAMPER EVIDENT BAND



PARTIAL BODY SLEEVE



MULTI-PACK SLEEVE



WIDE CONTAINER SLEEVE

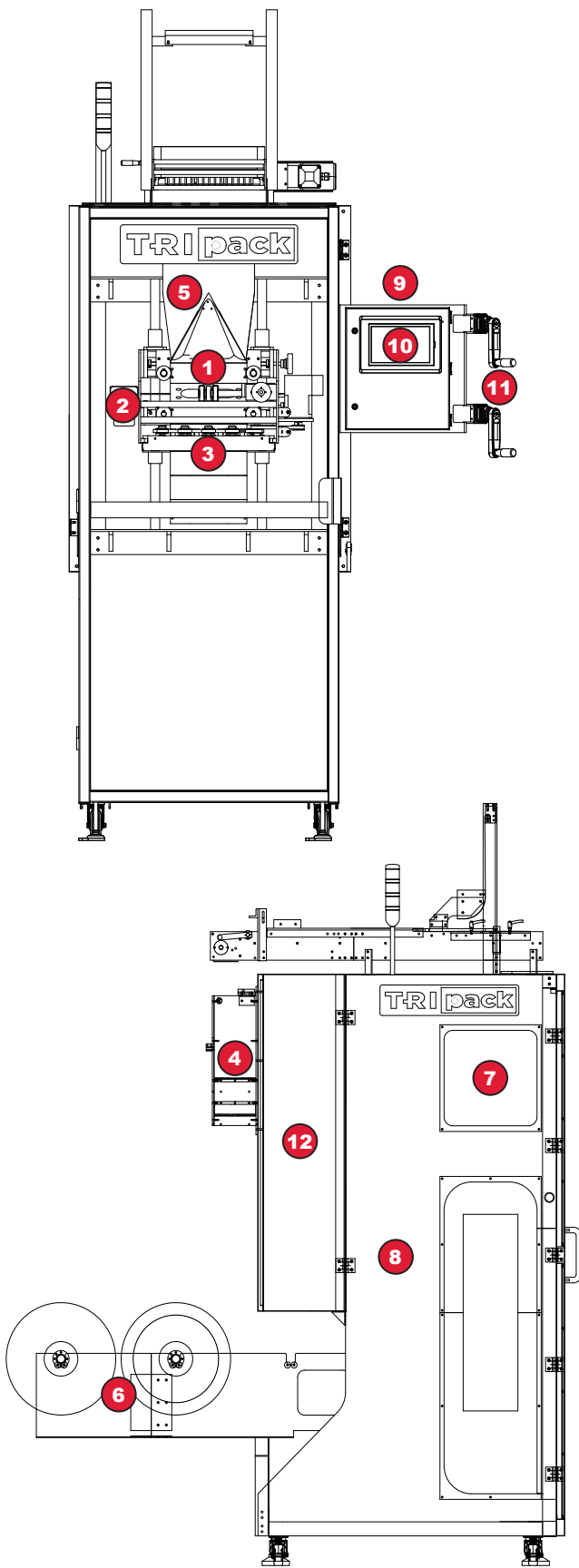

STANDARD SPECIFICATIONS*	
Standard Power	480 Volt, 3 Phase, 20 Amp
Product Range	1" – 6" Diameter
Lay Flat Range	40mm – 250mm
Cut Length Range	30mm – 330mm
Max Speed	250 ppm
Max Film Roll OD	19"
Film Core ID Sizes	5" or 10"
Film Gauge Tolerance	35-70 microns (1.38-2.75 mil)
Lay Flat Tolerance	-0mm / +1mm
Coefficient of Friction	≤ 0.25
Material Types	PET, PETG, OPS, PLA, PVC
Dimensions (LxWxH)	52" x 45" x 109"

*Other power options available, applicator stand is required if cut length exceeds 200mm and/or conveyor height exceeds 40", max speed is based on 40mm cut length

FEATURES

- 1 Eight-point mandrel/bullet design film delivery system with pre-form lower options based on container shape and size. Pre-calibrated clutch wheels for PERFECT mandrel placement and pressure tension
- 2 Servo-driven, high speed film delivery
- 3 Servo-driven multi-blade "Side Winder" knife assembly with special coated, dual sided blades for longer life
- 4 Powered film assist with zero tension film web design
- 5 Film turn assembly for accommodating multiple film entry points or odd shapes
- 6 Film loading/unwind station for 5" or 10" core/19" film
- 7 Interior lighting (head and applying area)
- 8 Carbon steel, powder coated frame with caster wheels and adjustable feet
 - Cantilever style design can run over existing conveyors when fully guarded
 - Locks into place with new or existing conveyor
- 9 Quick and easy changeover
 - Recipe-driven sizes in HMI
 - Tool-less (quick-change) knife assembly
 - Powered Siko counters for head, app wheels, product detect, and film registration adjustments
 - Improved access to film turn, registration eye adjustments, and application area
- 10 Allen-Bradley color touch screen HMI
- 11 Improved vertical adjustments for the head and application wheel assemblies
- 12 Allen-Bradley control system with CompactLogix PLC

INDUSTRY LEADING

